

FEATURES

- PEAK PULSE POWER= 600 W @ 1ms
- BREAKDOWN VOLTAGE RANGE :
From 6V8 to 220 V.
- UNI AND BIDIRECTIONAL TYPES
- LOW CLAMPING FACTOR
- FAST RESPONSE TIME
- UL RECOGNIZED

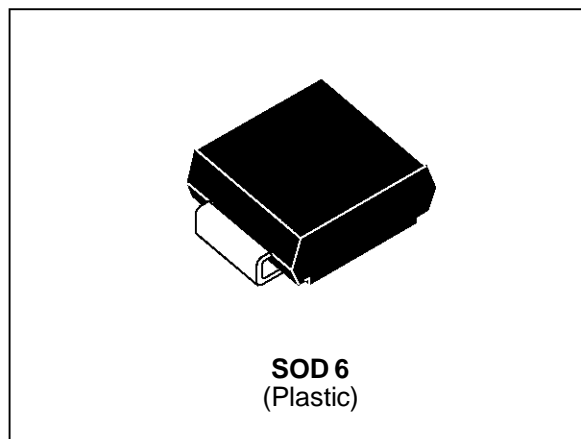

DESCRIPTION

Transil diodes provide high overvoltage protection by clamping action. Their instantaneous response to transients makes them particularly suited to protect voltage sensitive devices such as MOS Technology and low voltage supplied IC's.

ABSOLUTE MAXIMUM RATINGS (T_{amb} = 25°C)

Symbol	Parameter		Value	Unit
P _p	Peak pulse power dissipation		600	W
P	Power dissipation on infinite heatsink	T _{lead} = 50°C	4	W
T _{stg} T _j	Storage temperature range Maximum junction temperature		- 65 to + 175 150	°C °C
T _L	Maximum lead temperature for soldering during 10 s.		260	°C

THERMAL RESISTANCES

Symbol	Parameter	Value	Unit
R _{th (j-l)}	Junction to leads on infinite heatsink	25	°C/W
R _{th (j-a)}	Junction to ambient on printed circuit.	100	°C/W

SM6Txx

ELECTRICAL CHARACTERISTICS

(T_{amb} = 25°C)

Symbol	Parameter
V _{RM}	Stand-off voltage
V _{BR}	Breakdown voltage
V _{CL}	Clamping voltage
I _{RM}	Leakage current @ V _{RM}
I _{PP}	Peak pulse current
αT	Voltage temperature coefficient
V _F	Forward voltage drop V _F < 3.5V @ I _F = 50 A.

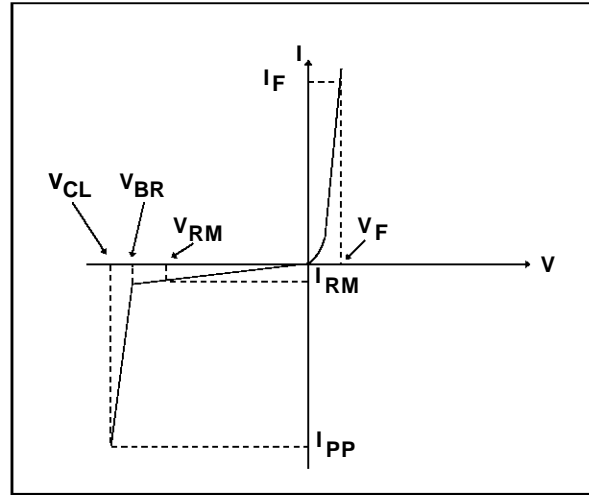

Types				I _{RM} @ V _{RM}		V _{BR} @ I _R				V _{CL} @ I _{PP}		V _{CL} @ I _{PP}		αT	C
				max		min	nom	max	max		max		max	typ	
						note2				10/1000μs		8/20μs		note3	note4
Uni directional	*	Bi directional	*	μA	V	V	V	V	mA	V	A	V	A	10 ⁻⁴ /°C	pF
SM6T6V8	DD	SM6T6V8C	LD	1000	5.8	6.45	6.8	7.48	10	10.5	57	13.4	298	5.7	4000
SM6T6V8A	DE	SM6T6V8CA	LE	1000	5.8	6.45	6.8	7.14	10	10.5	57	13.4	298	5.7	4000
SM6T7V5	DF	SM6T7V5C	LF	500	6.4	7.13	7.5	8.25	10	11.3	53	14.5	276	6.1	3700
SM6T7V5A	DG	SM6T7V5CA	LG	500	6.4	7.13	7.5	7.88	10	11.3	53	14.5	276	6.1	3700
SM6T10	DN	SM6T10C	LN	10	8.55	9.5	10	11	1	14.5	41	18.6	215	7.3	2800
SM6T10A	DP	SM6T10CA	LP	10	8.55	9.5	10	10.5	1	14.5	41	18.6	215	7.3	2800
SM6T12	DS	SM6T12C	LS	5	10.2	11.4	12	13.2	1	16.7	36	21.7	184	7.8	2300
SM6T12A	DT	SM6T12CA	LT	5	10.2	11.4	12	12.6	1	16.7	36	21.7	184	7.8	2300
SM6T15	DW	SM6T15C	LW	5	12.8	14.3	15	16.5	1	21.2	28	27.2	147	8.4	1900
SM6T15A	DX	SM6T15CA	LX	5	12.8	14.3	15	15.8	1	21.2	28	27.2	147	8.4	1900
SM6T18	ED	SM6T18C	MD	5	15.3	17.1	18	19.8	1	25.2	24	32.5	123	8.8	1600
SM6T18A	EE	SM6T18CA	ME	5	15.3	17.1	18	18.9	1	25.2	24	32.5	123	8.8	1600
SM6T22	EH	SM6T22C	MH	5	18.8	20.9	22	24.2	1	30.6	20	39.3	102	9.2	1350
SM6T22A	EK	SM6T22CA	MK	5	18.8	20.9	22	23.1	1	30.6	20	39.3	102	9.2	1350
SM6T24	EL	SM6T24C	ML	5	20.5	22.8	24	26.4	1	33.2	18	42.8	93	9.4	1250
SM6T24A	EM	SM6T24CA	MM	5	20.5	22.8	24	25.2	1	33.2	18	42.8	93	9.4	1250
SM6T27	EN	SM6T27C	MN	5	23.1	25.7	27	29.7	1	37.5	16	48.3	83	9.6	1150
SM6T27A	EP	SM6T27CA	MP	5	23.1	25.7	27	28.4	1	37.5	16	48.3	83	9.6	1150
SM6T30	EQ	SM6T30C	MQ	5	25.6	28.5	30	33	1	41.5	14.5	53.5	75	9.7	1075
SM6T30A	ER	SM6T30CA	MR	5	25.6	28.5	30	31.5	1	41.5	14.5	53.5	75	9.7	1075
SM6T33	ES	SM6T33C	MS	5	28.2	31.4	33	36.3	1	45.7	13.1	59.0	68	9.8	1000
SM6T33A	ET	SM6T33CA	MT	5	28.2	31.4	33	34.7	1	45.7	13.1	59.0	68	9.8	1000
SM6T36	EU	SM6T36C	MU	5	30.8	34.2	36	39.6	1	49.9	12	64.3	62	9.9	950
SM6T36A	EV	SM6T36CA	MV	5	30.8	34.2	36	37.8	1	49.9	12	64.3	62	9.9	950
SM6T39	EW	SM6T39C	MW	5	33.3	37.1	39	42.9	1	53.9	11.1	69.7	57	10.0	900
SM6T39A	EX	SM6T39CA	MX	5	33.3	37.1	39	41.0	1	53.9	11.1	69.7	57	10.0	900
SM6T68	FP	SM6T68C	NP	5	58.1	64.6	68	74.8	1	92	6.5	121	33	10.4	625
SM6T68A	FQ	SM6T68CA	NQ	5	58.1	64.6	68	71.4	1	92	6.5	121	33	10.4	625
SM6T100	FX	SM6T100C	NX	5	85.5	95.0	100	110	1	137	4.4	178	22.5	10.6	500
SM6T100A	FY	SM6T100CA	NY	5	85.5	95.0	100	105	1	137	4.4	178	22.5	10.6	500

Types				I _{RM} @ V _{RM}		V _{BR} @ I _R				V _{CL} @ I _{PP}		V _{CL} @ I _{PP}		αT	C	
				max		min	nom	max		max		max	max	max	typ	
Uni directional		*	Bi directional	*	μA	V	V	V	V	mA	V	A	V	A	10 ⁻⁴ /°C	pF
SM6T150	GK		SM6T150C	OK	5	128	143	150	165	1	207	2.9	265	15	10.8	400
SM6T150A	GL		SM6T150CA	OL	5	128	143	150	158	1	207	2.9	265	15	10.8	400
SM6T200	GT		SM6T200C	OT	5	171	190	200	220	1	274	2.2	353	11.3	10.8	350
SM6T200A	GU		SM6T200CA	OU	5	171	190	200	210	1	274	2.2	353	11.3	10.8	350
SM6T220	GV		SM6T220C	OV	5	188	209	220	242	1	328	2	388	10.3	10.8	330
SM6T220A	GW		SM6T220CA	OW	5	188	209	220	231	1	328	2	388	10.3	10.8	330

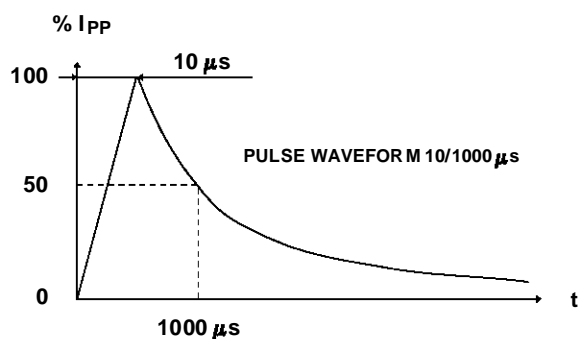
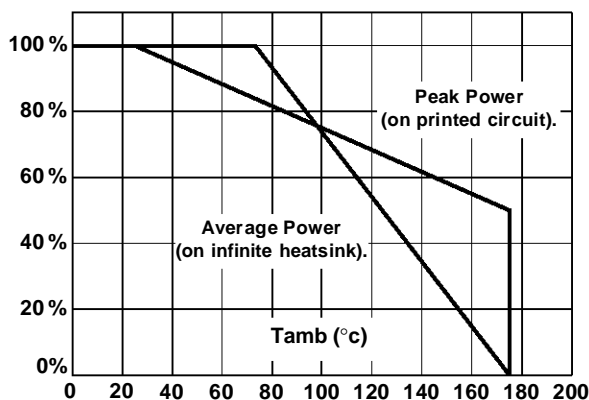

Fig. 1: Power dissipation derating versus ambient temperature



Note 1 : For surges greater than the maximum values, the diode will present a short-circuit Anode - Cathode.

Note 2 : Pulse test : t_p < 50 ms.

Note 3 : ΔV_{BR} = αT * (T_{amb} - 25) * V_{BR}(25°C).

Note 4 : V_R = 0 V, F = 1 MHz. For bidirectional types, capacitance value is divided by 2.

Fig. 2 : Peak pulse power versus exponential pulse duration.

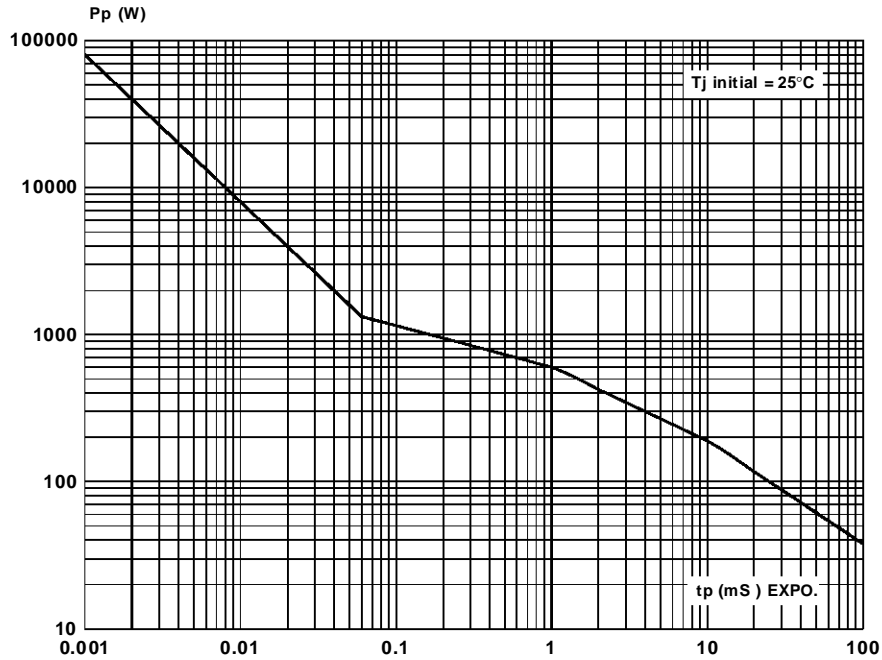
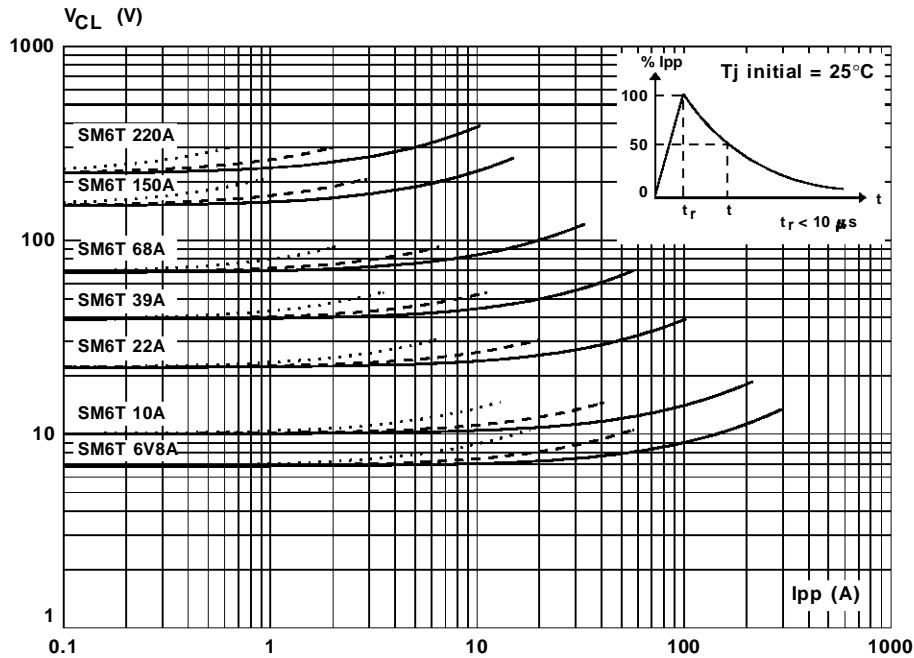

Fig. 3 : Clamping voltage versus peak pulse current.

Exponential waveform $t_p = 20 \mu s$ _____
 $t_p = 1 ms$ _____
 $t_p = 10 ms$



Note : The curves of the figure 3 are specified for a junction temperature of 25 °C before surge.
 The given results may be extrapolated for other junction temperatures by using the following formula :
 $\Delta V_{BR} = \alpha T \cdot [T_{amb} - 25] \cdot V_{BR}(25^\circ C)$
 For intermediate voltages, extrapolate the given results.

Fig. 4a : Capacitance versus reverse applied voltage for unidirectional types (typical values).

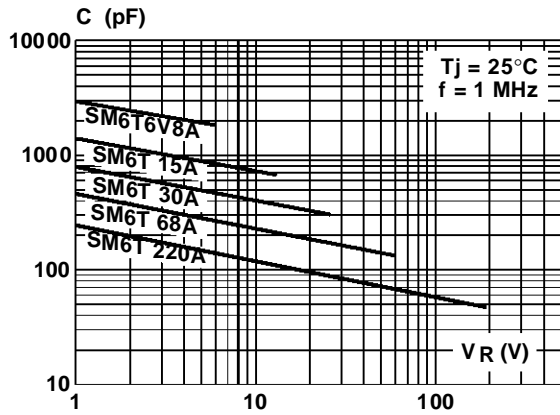

Fig. 4b : Capacitance versus reverse applied voltage for bidirectional types (typical values).

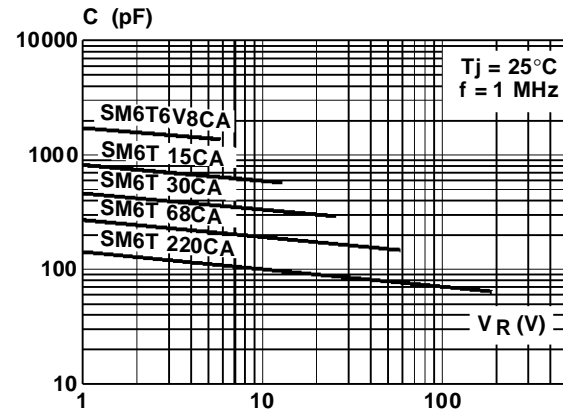

Fig. 5 : Peak forward voltage drop versus peak forward current (typical values for unidirectional types).

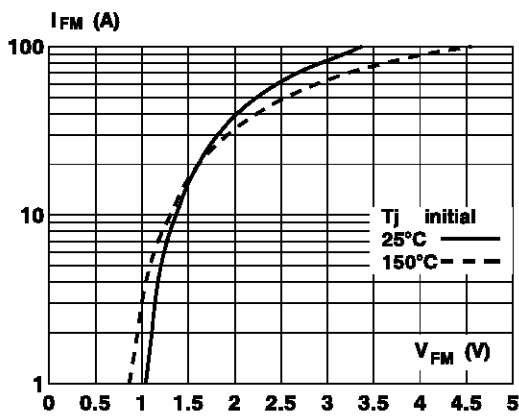
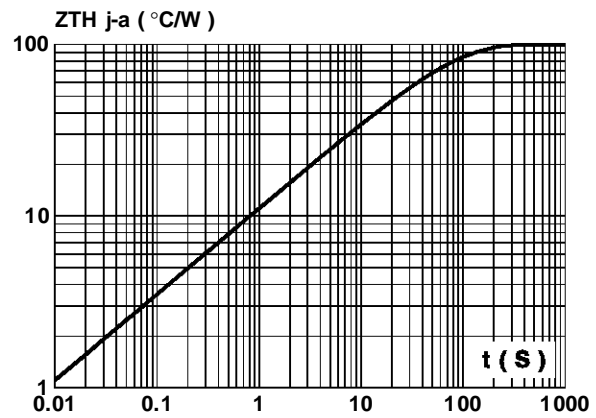
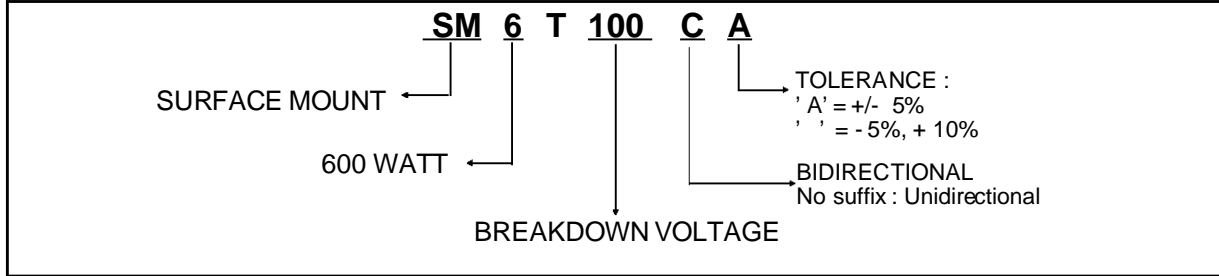

Fig. 6 : Transient thermal impedance junction-ambient versus pulse duration. For a mounting on PC Board with standard footprint dimensions.



SM6Txx

ORDER CODE



MARKING : Logo, Date Code, Type Code, Cathode Band (for unidirectional types only).

PACKAGE MECHANICAL DATA

SOD 6 (Plastic)

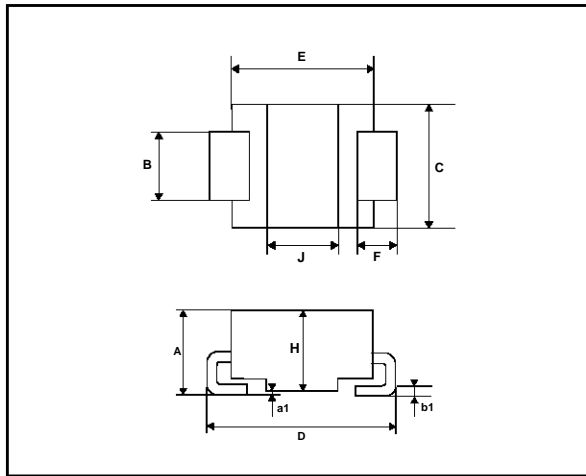

REF.	DIMENSIONS			
	Millimeters		Inches	
	Min.	Max.	Min.	Max.
A	2.44	2.62	0.096	0.103
a1	0.10	0.20	0.004	0.008
B	1.96	2.11	0.077	0.083
b1	0.25	0.35	0.010	0.014
C	3.65	3.93	0.143	0.155
D	5.39	5.59	0.212	0.220
E	4.15	4.30	0.163	0.170
F	1.00	1.27	0.039	0.050
H	2.33	2.41	0.092	0.095
J	2.05	2.13	0.080	0.084

FOOTPRINT DIMENSIONS (Millimeter)

SOD 6 Plastic.

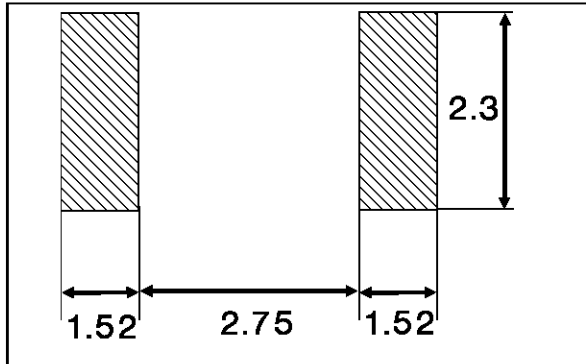

Packaging : standard packaging is in film.

Information furnished is believed to be accurate and reliable. However, SGS-THOMSON Microelectronics assumes no responsibility for the consequences of use of such information nor for any infringement of patents or other rights of third parties which may result from its use. No license is granted by implication or otherwise under any patent or patent rights of SGS-THOMSON Microelectronics. Specifications mentioned in this publication are subject to change without notice. This publication supersedes and replaces all information previously supplied. SGS-THOMSON Microelectronics products are not authorized for use as critical components in life support devices or systems without express written approval of SGS-THOMSON Microelectronics.

© 1995 SGS-THOMSON Microelectronics - Printed in Italy - All rights reserved.

SGS-THOMSON Microelectronics GROUP OF COMPANIES

Australia - Brazil - France - Germany - Hong Kong - Italy - Japan - Korea - Malaysia - Malta - Morocco - The Netherlands - Singapore - Spain - Sweden - Switzerland - Taiwan - Thailand - United Kingdom - U.S.A.